

DVJ WHISPAIR, frame 721J

ROOTS® DVJ WHISPAIR™ Dry Vacuum Exhausters

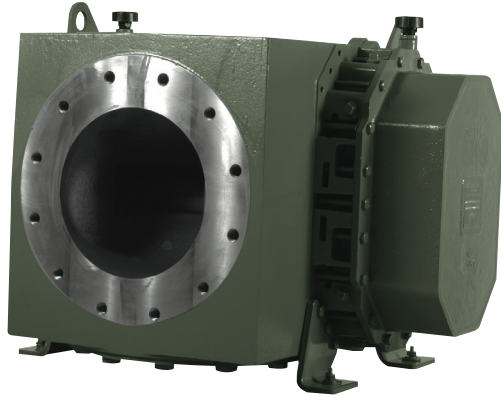

Design and Construction Features

- Rigid cast iron cylinder and headplates
- Anti-friction cylindrical roller bearings
- Splash lubricated spur timing gears
- Inlet and discharge connections in standard pipe sizes
- Involute profile ductile iron impellers

ROOTS® DVJ WHISPAIR™ dry exhausters have an exclusive discharge jet plenum design which allows cool, atmospheric air to flow into the cylinder. This unique design permits continuous operation at vacuum levels to blank-off with a single stage unit.

Basic dry vacuum pump description

Standard dry exhausters are limited to approx. 16" Hg vacuum because operation at higher vacuum levels can cause extreme discharge temperatures resulting in casing & impeller distortion and possible seizure. The DVJ vacuum exhauster's integral cooling design eliminates the problems associated with high temperatures at vacuum levels beyond 16" Hg.

DVJ WHISPAIR exhausters are heavy-duty units with integral-shaft ductile iron impellers. The casing, headplates, gear cover and drive end cover are grey iron. Carburized and ground alloy steel spur timing gears are taper mounted on the shafts, secured with a locknut. Cylindrical roller bearings are splash lubricated at both the gear end and drive end. Piston rings reduce air leakage through the headplate bores and lip-type oil seals prevent lubricants from entering the air chamber. Rugged steel mounting feet permit infield adaptability to either vertical or horizontal installation requirements.

ROOTS DVJ WHISPAIR exhausters can be arranged to operate in two and three stage systems to achieve vacuum levels down to 1 Torr.

Warranty period

Twelve (12) months from date of original unit start-up or 18 months from date of original shipment, whichever occurs first.

Operating principle

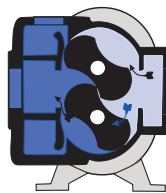

Position 1

Incoming air is trapped between the impellers. Simultaneously, pressurized air is being discharged.



Position 2

As the upper impeller passes the jet plenum, cooled, pressurized air flows into the space between the impeller and cylinder. This cools the trapped air, helps control thermal growth and allows higher discharge pressures.

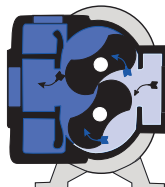

Position 3

The trapped air is then moved into the discharge flange (left). Backflow is reduced, resulting in lower operating noise level and reduced shock loading on the impellers.

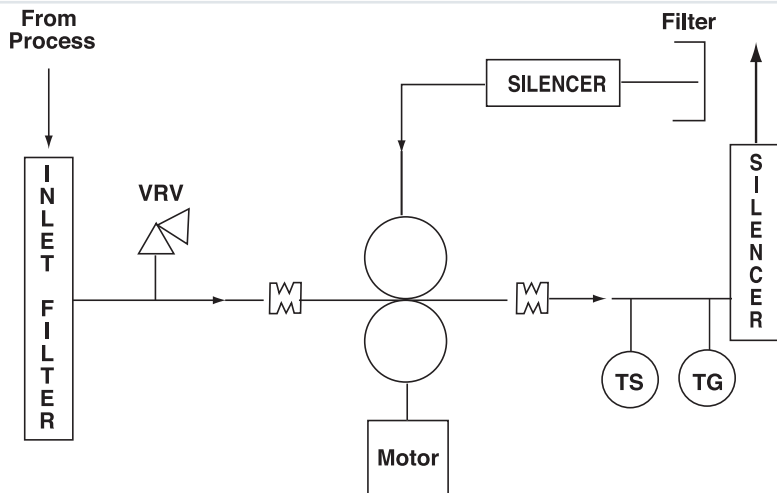

For further information contact:

ROOTS
 900 W. Mount Street,
 Connersville Indiana, 47331
 USA

Tel: +1 765 827 9200
Web: www.RootsBlower.com

Performance table

Frame size	Speed RPM	Maximum free air CFM	16" HGV		20" HGV		24" HGV		27" HGV	
			CFM	BHP	CFM	BHP	CFM	BHP	CFM	BHP
721J	1180	-	975	57.2	755	71.2	333	85.2	*	95.7
	1770	-	1806	87	1585	107.7	1163	128.3	122	143.8
	2200	-	2411	109.6	2190	134.8	1768	160.1	727	179.1
	2600	3658	2973	131.4	2753	160.7	2331	190	1290	212

Notes: *Denotes blank-off. Ratings based on inlet and jet air at standard temperature of 68oF, discharge and jet pressure of 30"HGV and specific gravity of 1.0. Refer to factory for performance guarantee above 24" HGV.

Outline drawing and dimensional table

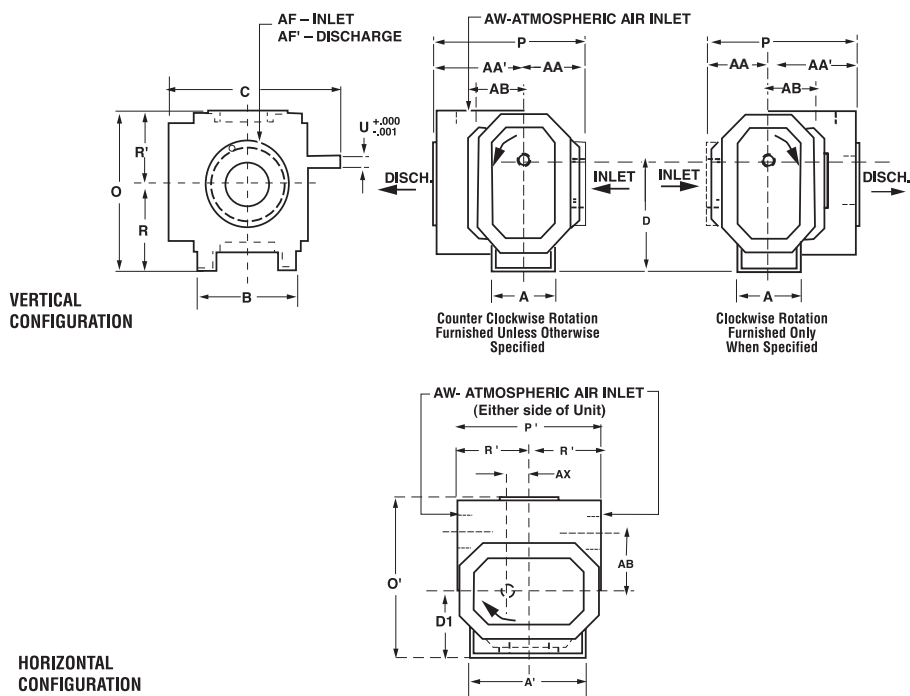

Frame Size	A	A'	B	C	Drive shaft location		O	O'	P	P'	R	U	Keyway	AA	AA'	AB	AF	AF'	AW	AX	Approx net Wt. (lbs)
					D	D1															
721J	19.00	26.00	27.00	39.38	17.00	10.00	24.88	25.25	24.25	22.75	13.50	2.375	.625 x .313	9.00	15.25	5.50	12 FLG	12 FLG	12 FLG	3.50	1750

Notes: 1. All dimensions are in inches. 2. Weights are in pounds, and are approximate. 3. Do not use for construction.